

Example Process Models

Process Decomposition

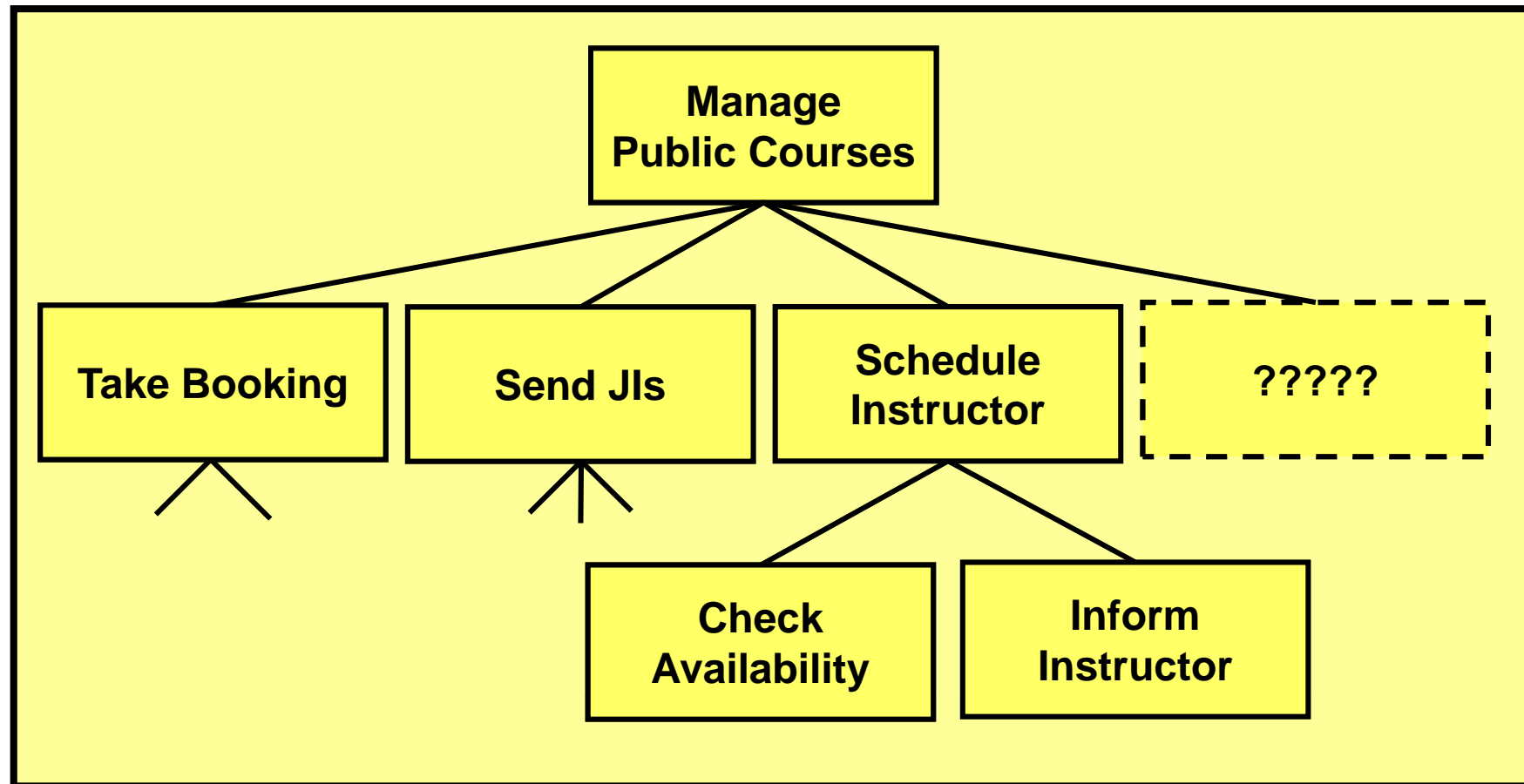

Example Data Flow Diagram

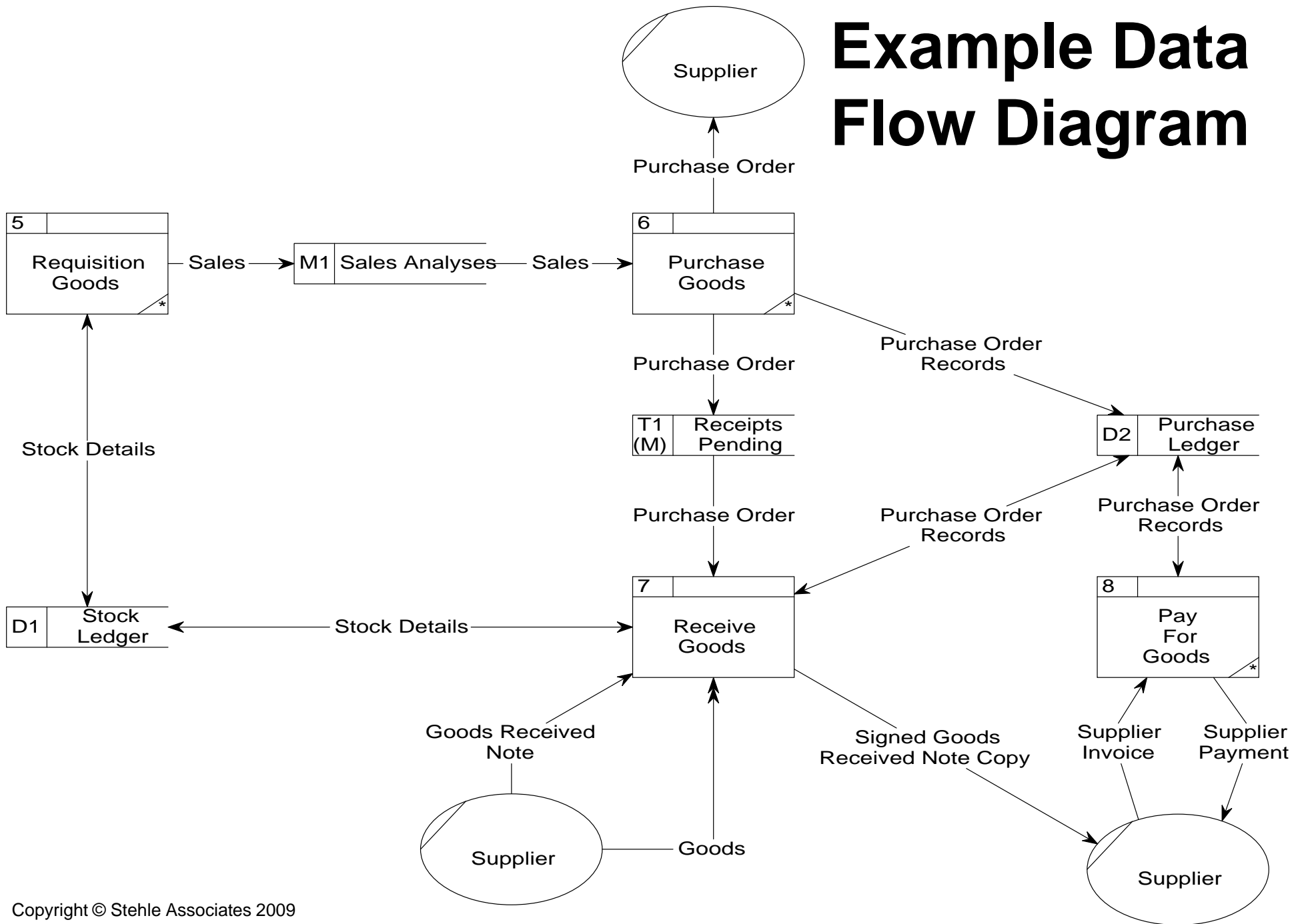

UML Activity Diagram

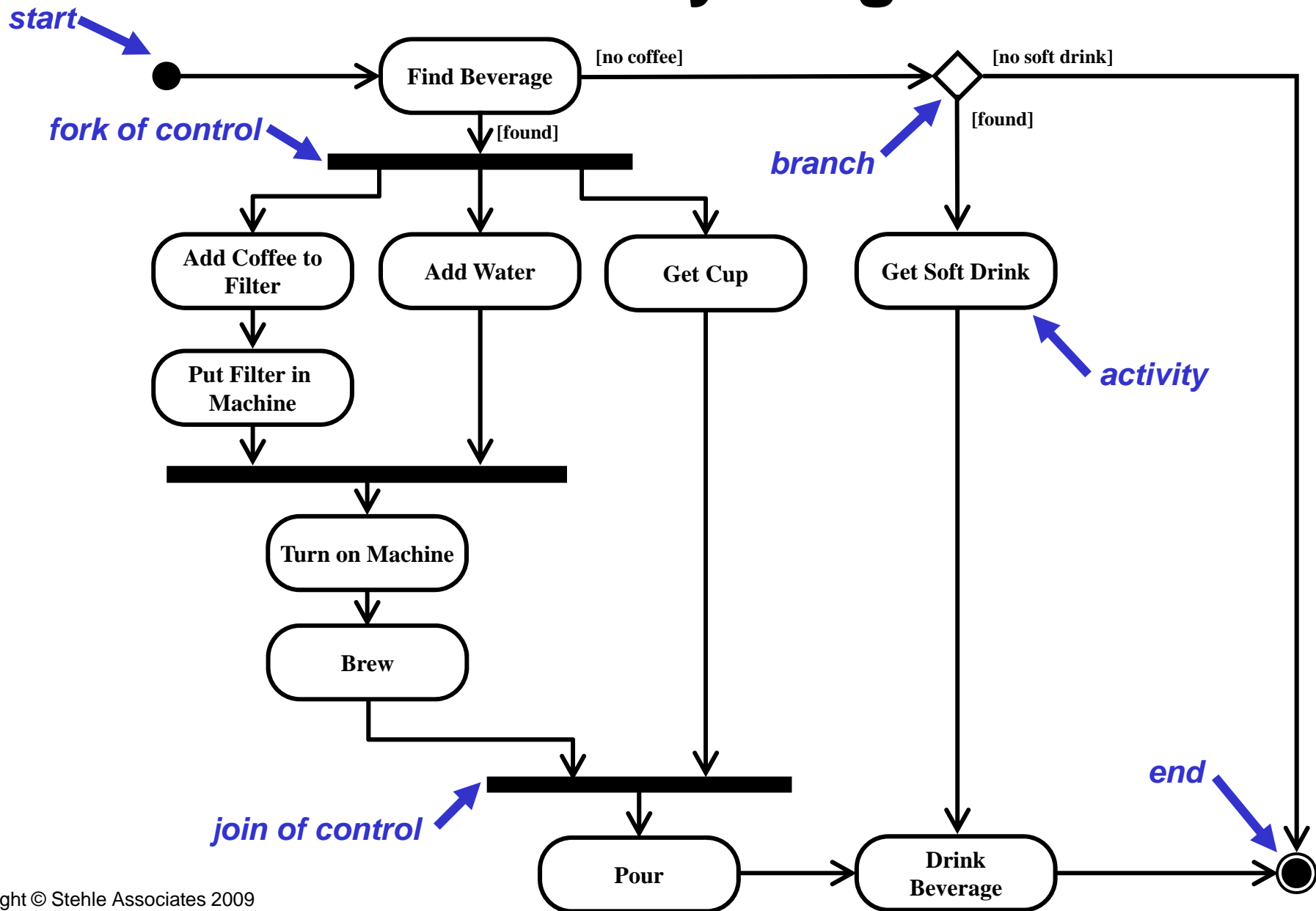

Process Map - Example

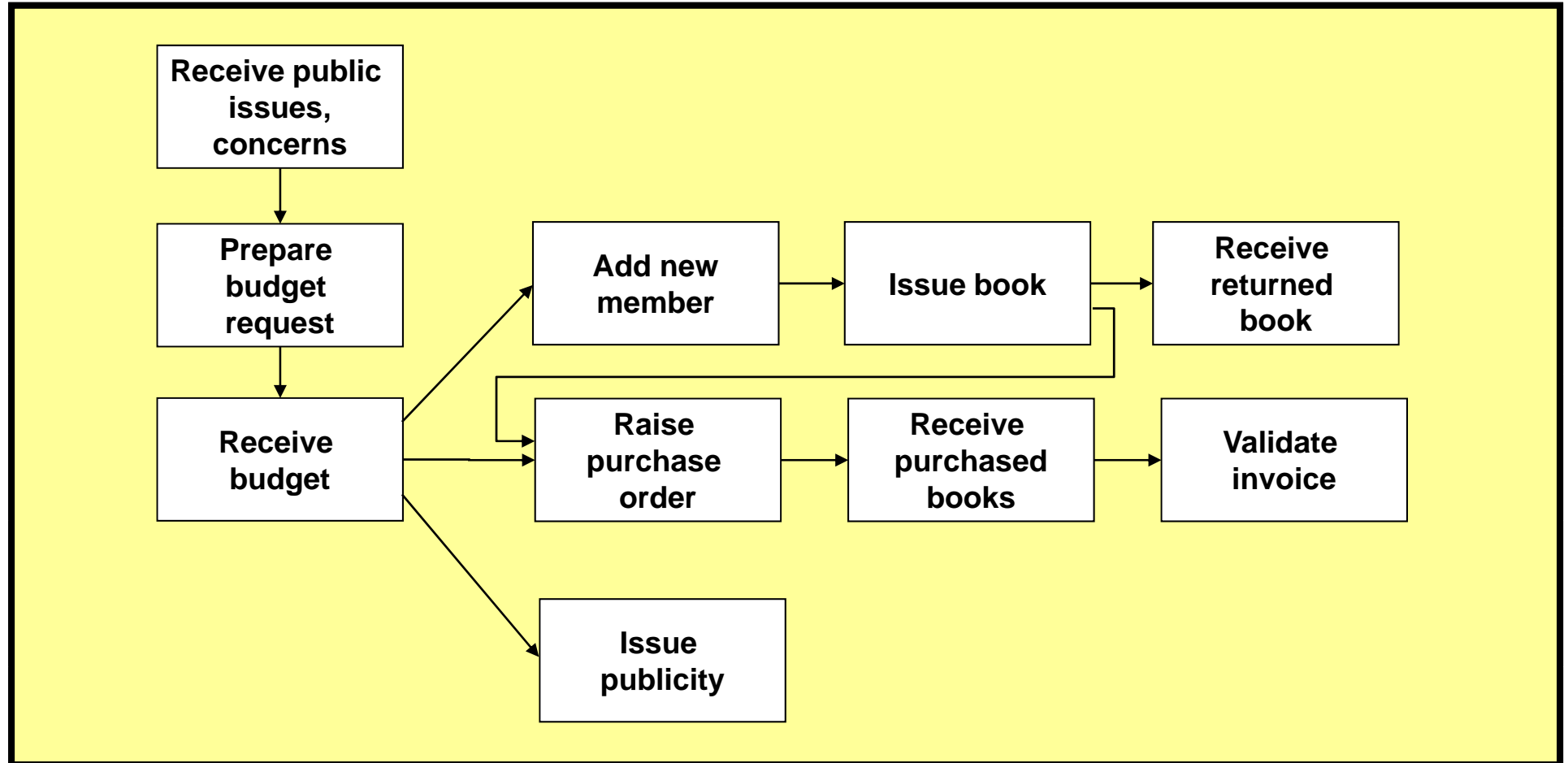

ABC Stockbrokers – Buying UK Shares

Solution 6 – Transact Order

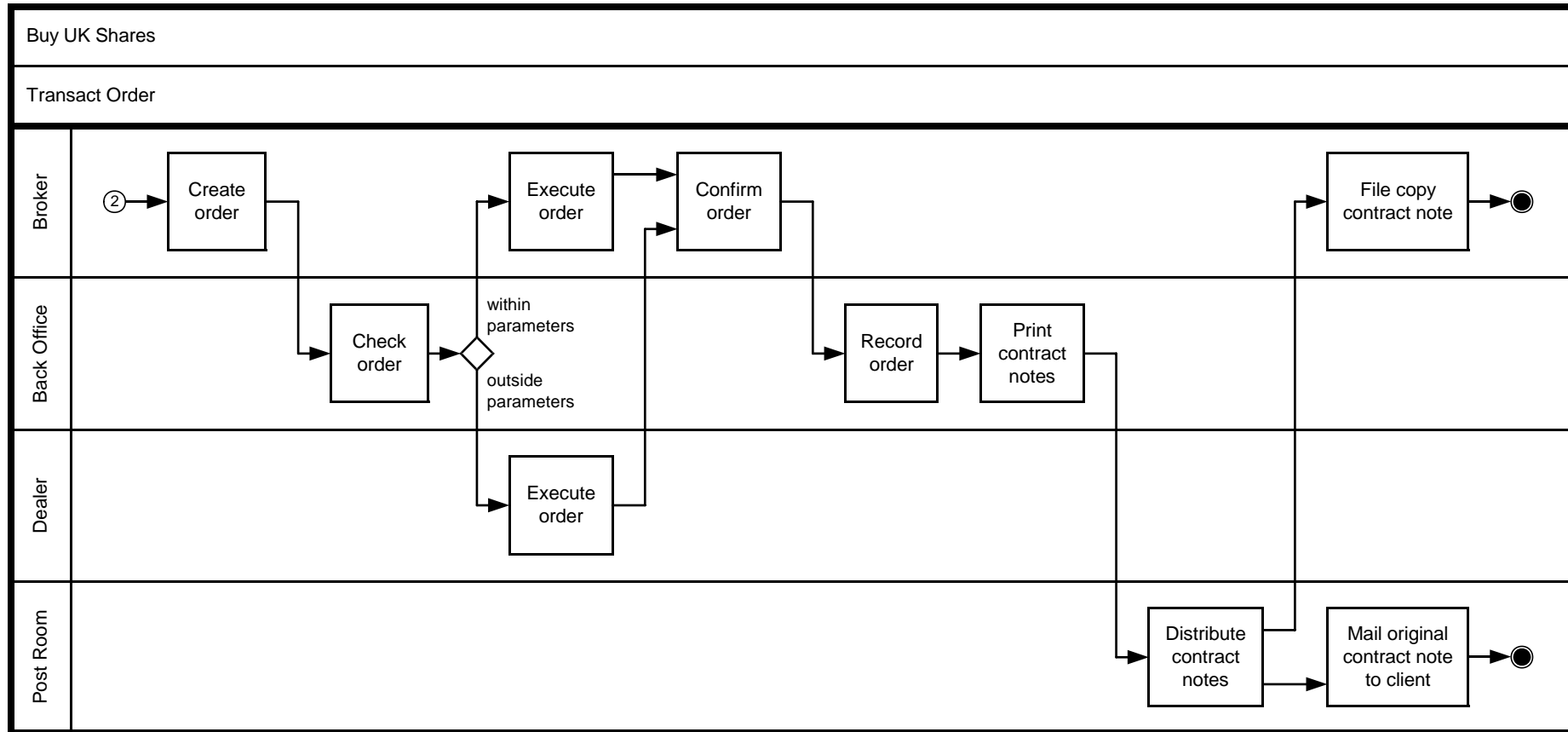

ABC Stockbrokers – Buying UK Shares

Solution 8 – Settle Order (option 2)

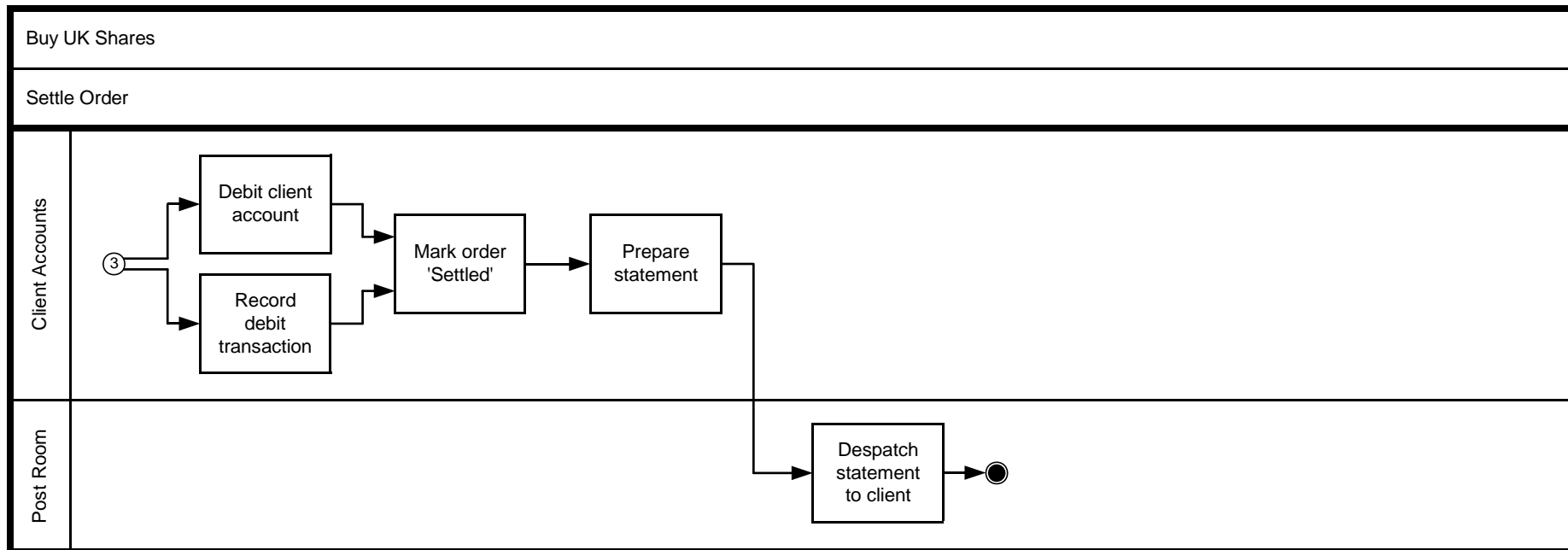

ABC Stockbrokers – Buying UK Shares

Solution 9 – Settle Order (option 3)

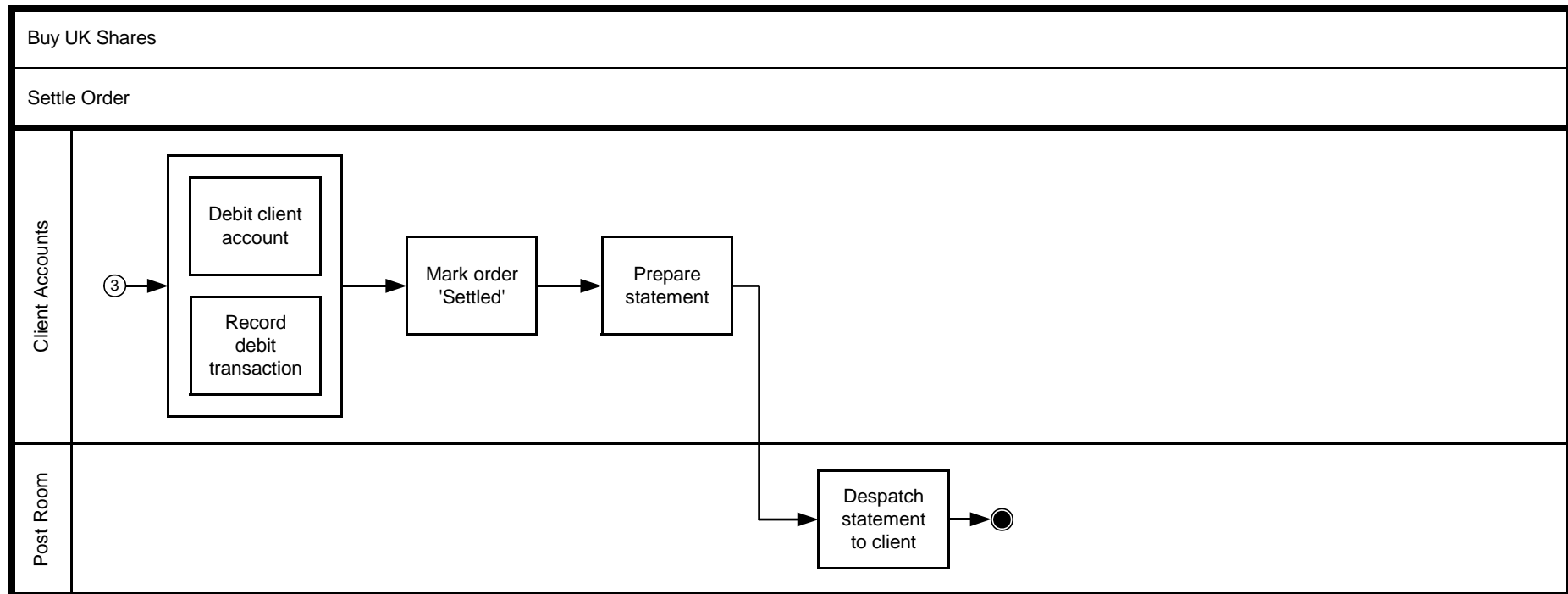

Stehle Credit Financing

Solution 5 – Approve Loan Application

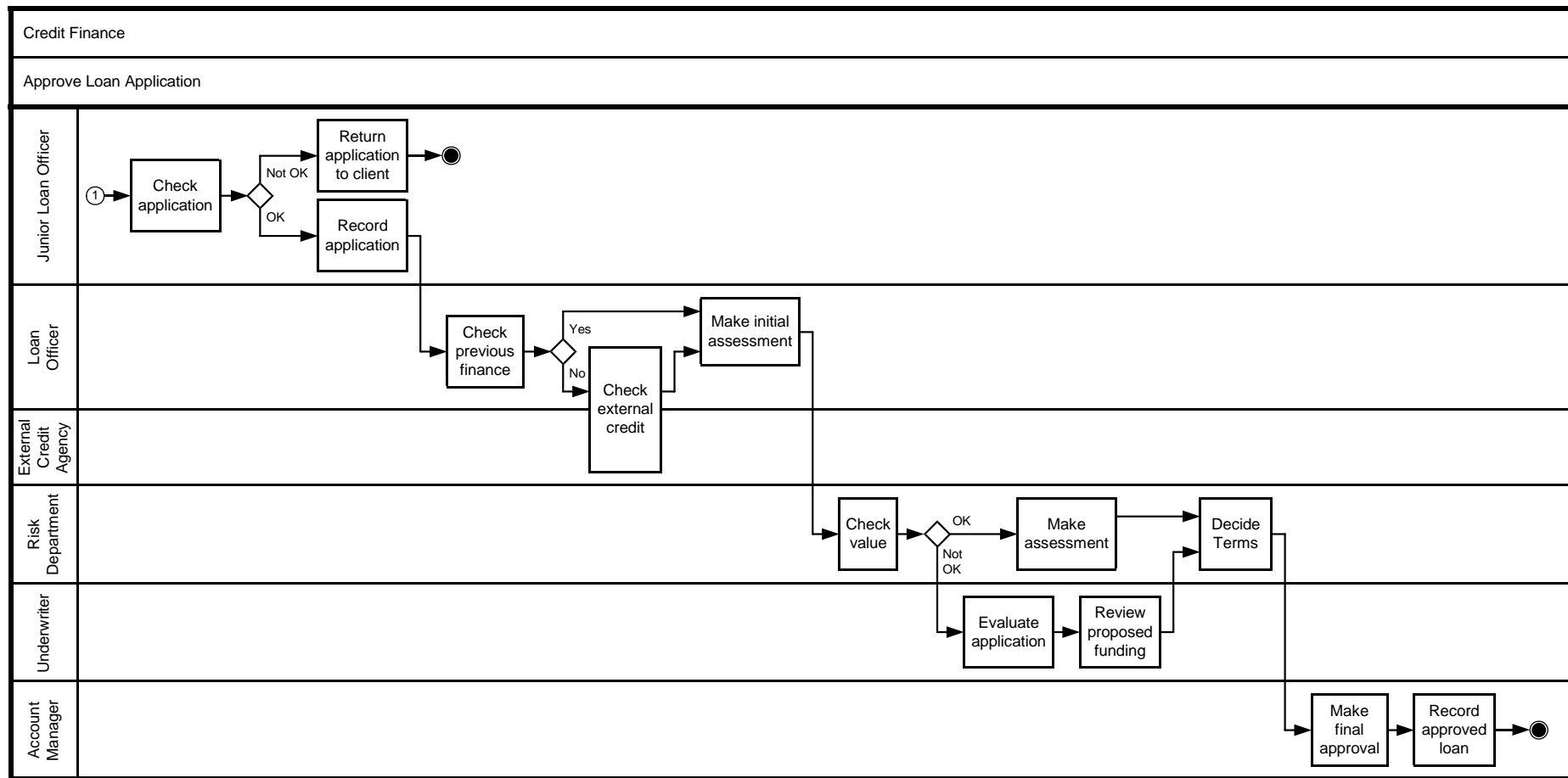

HPS Customer Service Management

Solution 4 – Process Map – Elementary Process Level

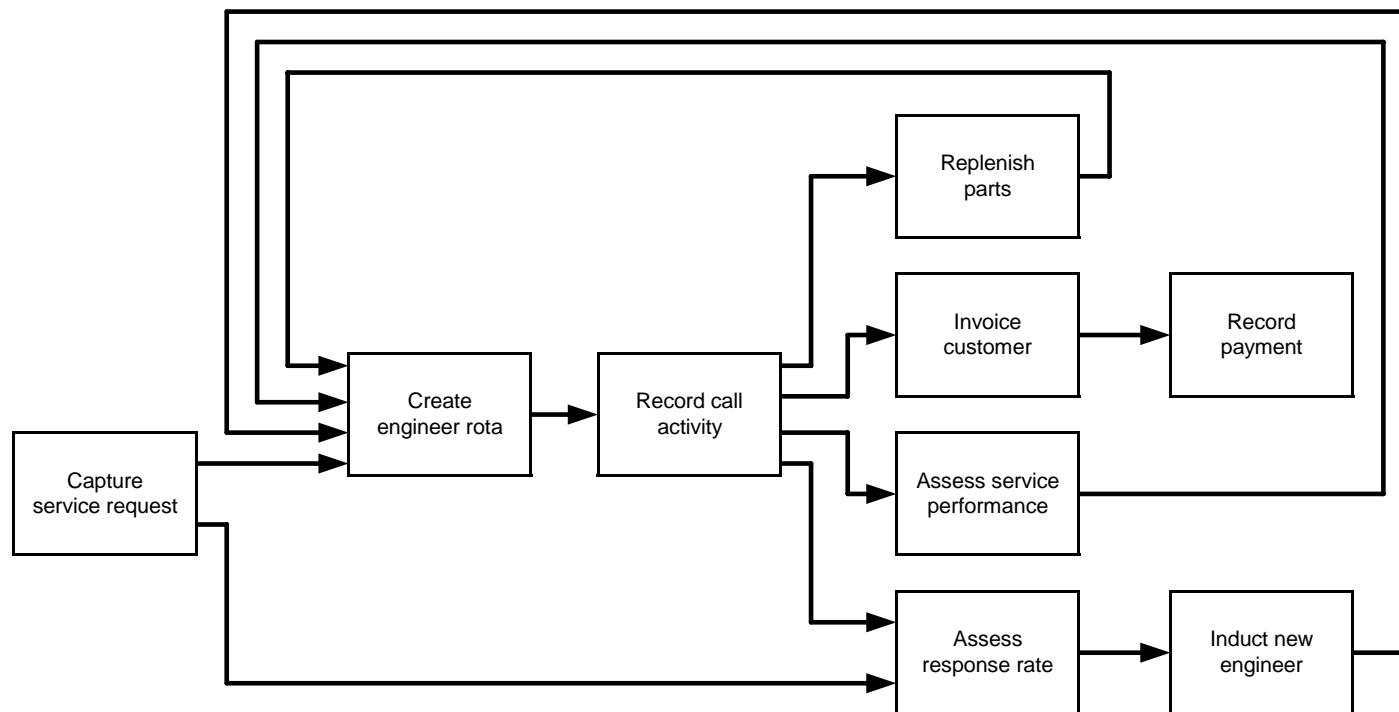

HPS Customer Service Management

Solution 5 – Capture Service Request

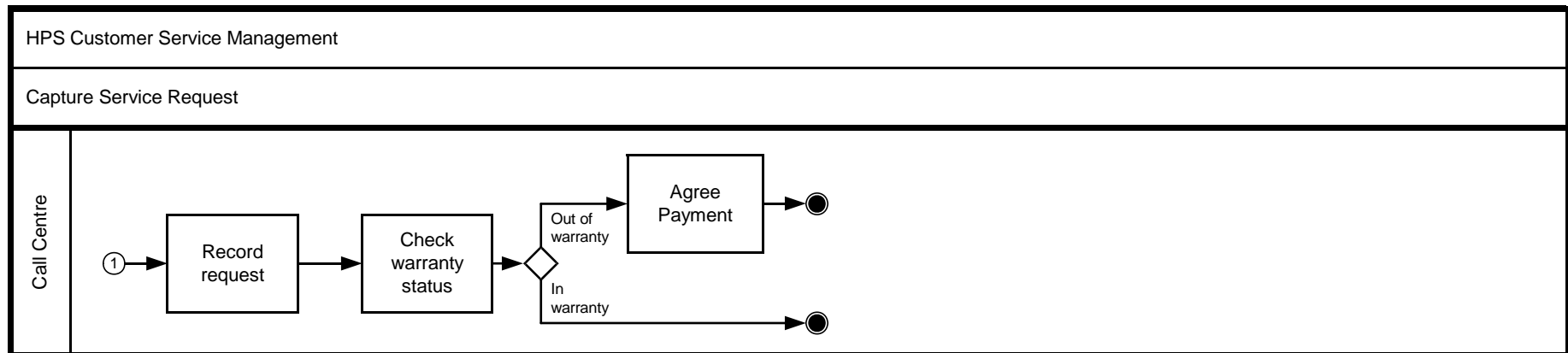

HPS Customer Service Management

Solution 7 – Create Engineer Rota (Option 2)

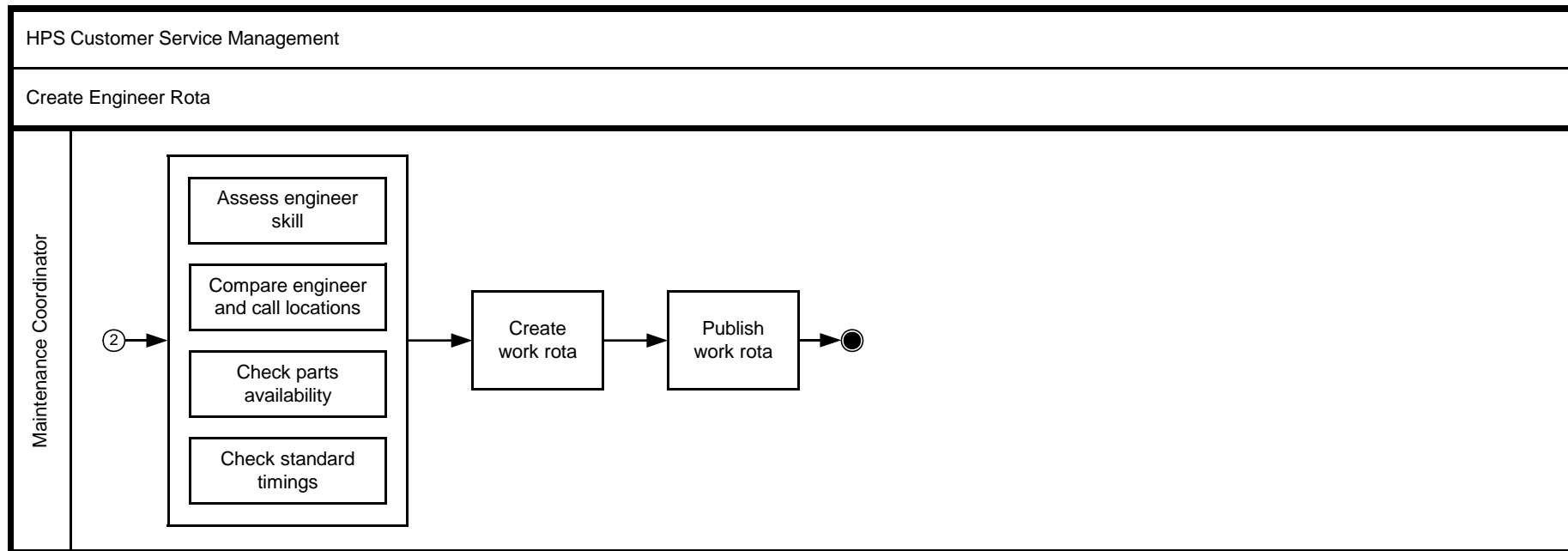

HPS Customer Service Management

Solution 17 – Service Equipment

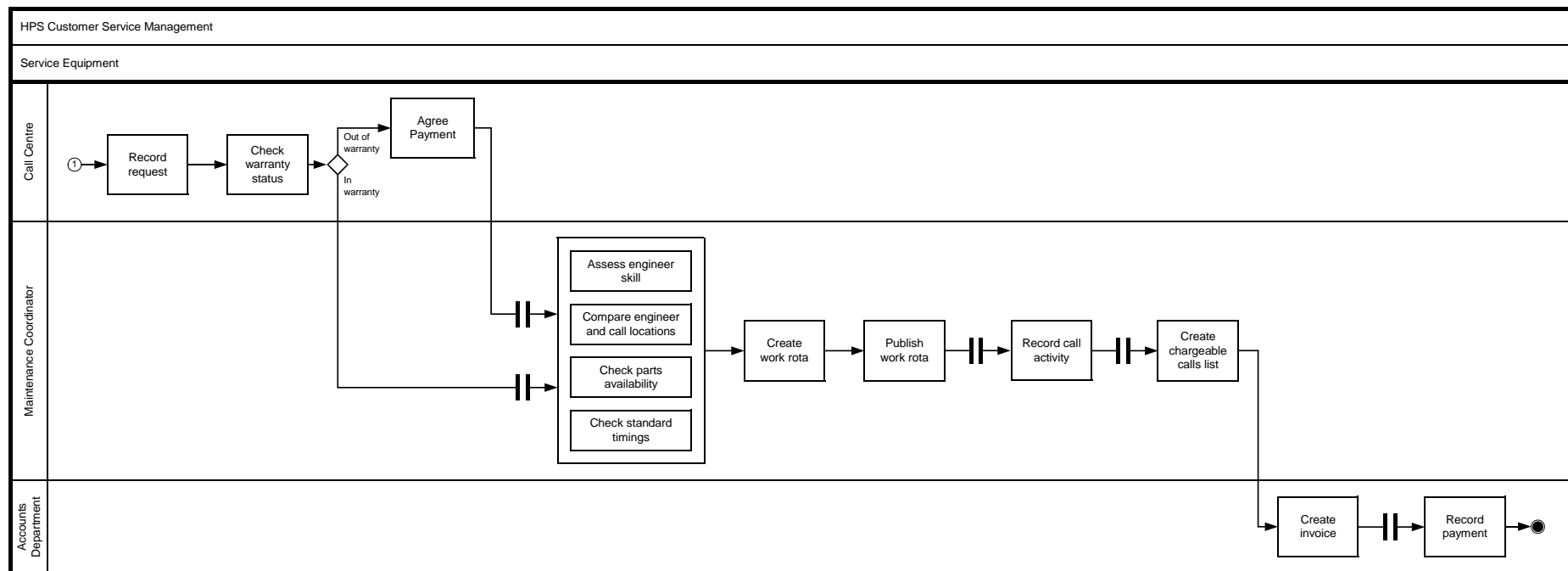

Sir Edward Kelly Ltd Exercise 7 Solution

Develop a process model for the base (no problem) scenario in the use case from Exercise 6.

